

driade

NEOZ by Philippe Starck

ISTRUZIONI DI MONTAGGIO
ASSEMBLY INSTRUCTIONS
MONTAGE ANWEISUNGEN
INSTRUCTIONS DE MONTAGE

driade s.p.a. via Padana Inferiore 12 cap.29012 Fossadello
di Caorso (PC) Italy t.+39 0523818618 fax+39 0523822628
Domestic Sales t.+39 0523818650 fax +39 0523822628 e-mail:
com.it@driade.com International Sales t.+390523818660 fax
+39 0523822360 e-mail:export@driade.com www.driade.com

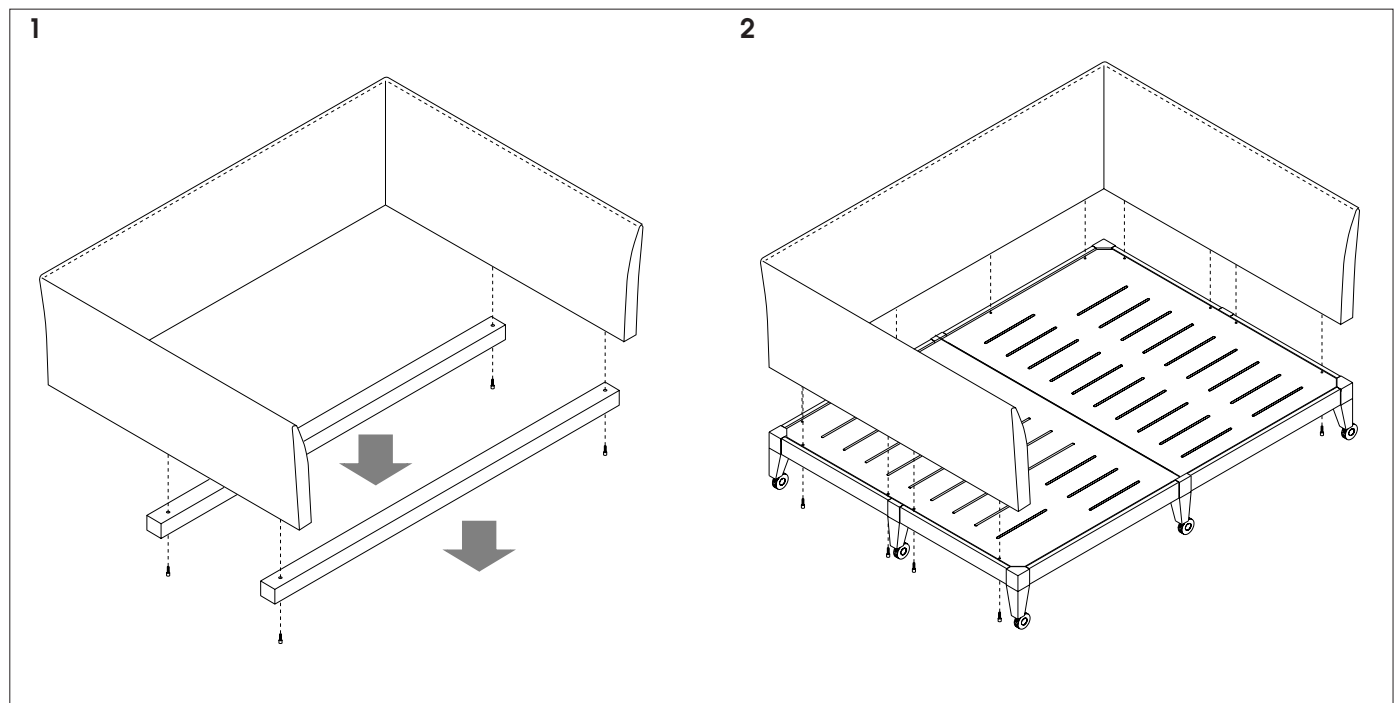
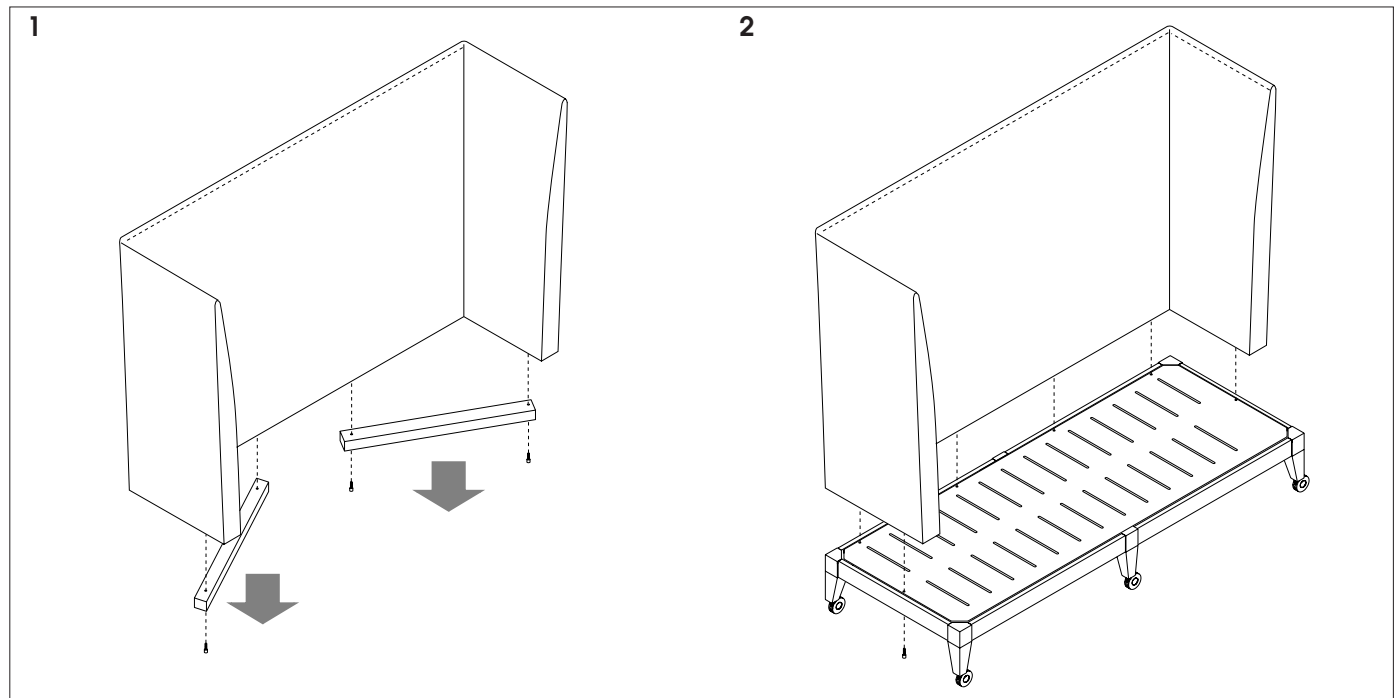

Materiali:

Struttura in legno di mogano con finitura in vernice poliuretana; ruote in pressofusione di zama e nylon verniciate con polvere epossidica. Sedile e schienale imbottiti con schiume poliuretatiche e ovatta; cuscini in ovatta. Rivestimento sfoderabile in lino di colore bianco o in tessuto.

Manutenzione:

Rivestimento :

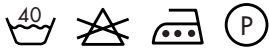

Parti verniciate e ruote:

pulire con panno e detergenti liquidi neutri di uso domestico; evitare l'uso di solventi (trielina, acetone), alcool e prodotti abrasivi.

Dimensioni:

2 posti	L. 146; P. 82; H. 85; seduta H. 45
3 posti	L. 206; P. 82; H. 85; seduta H. 45
3 posti schienale alto	L. 207; P. 88; H. 156; seduta H. 45
3 posti sedile profondo	L. 206; P. 152; H. 85; seduta H. 45
dormeuse	L. 64; P. 184; H. 42
pouf	L. 49; P. 49; H. 42

Materials:

Mahogany wood structure, coated with a polyurethanic varnish. Pressure die-cast 'zamak' and nylon wheels coated with an epoxy powder paint. Back and seat padded with polyurethanic foams and wadding; cushions stuffed with wadding. White linen or fabric detachable loose covers.

Maintenance:

Loose cover:



Wheels and varnished parts:

clean with cloth and neutral liquid domestic detergents: avoid using solvents (acetone, trichloroethylene), alcohol and abrasive products.

Dimensions:

2 seater	W. 146; D. 82; H. 85; seat H. 45
3 seater	W. 206; D. 82; H. 85; seat H. 45
3 seater with high back	W. 207; D. 88; H. 156; seat H. 45
3 seater with deep seat	W. 206; D. 152; H. 85; seat H. 45
day bed	W. 64; D. 184; H. 42
pouf	W. 49; D. 49; H. 42

Materialien:

Struktur aus Mahagoniholz. Lackierung aus Polyurethanlack. Rollen in pulverbeschichtetem Preßguß aus Zamak und Nylon. Sitzfläche und Rückenlehne mit Polsterung aus Polyurethanschäum und Watte. Kissen aus Watte. Abnehmbarer Bezug aus weißem Leinen oder Stoff.

Pflegeanleitung:

Bezug:

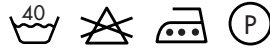

Lackierte Strukturteile und Rollen: Mit Tuch und neutralem, flüssigem Haushaltsreinigungsmittel reinigen. Den Gebrauch von Lösungen (Trichloräthylen, Aceton), Alkohol und Scheuermitteln vermeiden.

Maße:

Zweisitziges	B. 146; T. 82; H. 85; Sitzhöhe H. 45
Dreisitziges	B. 206; T. 82; H. 85; Sitzhöhe H. 45
Dreisitziges mit hoher Rückenlehne	B. 207; T. 88; H. 156; Sitzhöhe H. 45
Dreisitziges mit tiefer Sitzfläche	B. 206; T. 152; H. 85; Sitzhöhe H. 45
dormeuse	B. 64; T. 184; H. 42
hocker	B. 49; T. 49; H. 42

Matériaux:

Structure en bois d'acajou recouvert de vernis polyuréthanique; roulettes en alliage d'aluminium et nylon peintes avec une poudre époxyde. Assise et dossier rembourrés avec de la mousse polyuréthane et ouate; coussins en ouate. Revêtement amovible en lin blanc ou tissu.

Entretien:

revêtement:

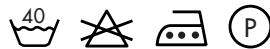

Parties peintes et roulettes:

nettoyer avec un chiffon et des nettoyants liquides neutres; éviter l'utilisation de dissolvants (acétone, trichloréthylène) et produits abrasifs.

Dimensions:

2 places	L. 146; P. 82; H. 85; assise H. 45
3 places	L. 206; P. 82; H. 85; assise H. 45
3 places dossier haut	L. 207; P. 88; H. 156; assise H. 45
3 places assise profonde	L. 206; P. 152; H. 85; assise H. 45
dormeuse	L. 64; P. 184; H. 42
pouf	L. 49; P. 49; H. 42

